

## T7771A Remote Temperature Sensor

### PRODUCT DATA



### GENERAL

The T7771A Remote Temperature Sensors are direct wired wall modules for use with the Honeywell T7350 Commercial Programmable Thermostat. The T7771A has a space temperature sensor, LED pushbutton setpoint adjustment, and override with LED.

### SPECIFICATIONS

**Construction:** Two-piece construction, cover and internally wired subbase. Field wiring 14 to 22 AWG (2.0 to 0.34 sq. mm) connects to a terminal block in the subbase. Wall module is activated by plugging into prewired subbase.

**Mounting Options:**

The T7771 can be mounted on a standard two by four inch junction box or on a 60 mm diameter junction box.

**Dimensions (H/W/D):**

5-1/16 x 3-1/8 x 1 in. (128 x 80 x 25 mm).

**Setpoint Adjustment:**

The setpoint offset allows for  $\pm 3^{\circ}\text{F}$  from the programmed T7350 setpoint.

**Environmental Ratings:**

Operating Temperature: 45° to 99°F (7° to 37°C).  
Shipping Temperature: -40° to 150°F (-40° to 65°C).

### FEATURES

- Pushbutton setpoint adjustment with LED indicators.
- Occupied/unoccupied override (bypass) with LED.
- LONWORKS® bus jack.
- Operating range 45 to 99°F (7 to 37°C).

### IMPORTANT

- The T7771 compatibility with the T7350 only applies to T7350 models with date code 0423 or later.
- To ensure the purchase of a compatible T7350, order either:
  - Y7355B1002 (consisting of: T7350B Thermostat, T7771A and C7041B Sensors).
  - Y7355D1008 (consisting of: T7350D Thermostat, T7771A, C7041B Sensors).

**Relative Humidity:** 5% to 95% noncondensing.

**Temperature Sensor Operating Range:**  
45 to 99°F (10 to 37°C).

### Temperature Sensor Accuracy

**T7771A 20K Ohm Nonlinearized Sensor:**

All T7771 models are furnished with a 20K Ohm nonlinear NTC temperature sensor that follows a specific temperature-resistance curve. See Fig. 1. Sensor accuracy at 77°F is  $\pm 0.36^{\circ}\text{F}$  ( $\pm 0.2^{\circ}\text{C}$ ) See form 63-7074 for detailed nominal temperature resistance output in table form.

**NOTE:** In addition, a jumper allows for 10K Ohm output to accommodate using multiple sensors for temperature averaging applications with the T7350 Commercial Thermostat. See the Wiring section for details.



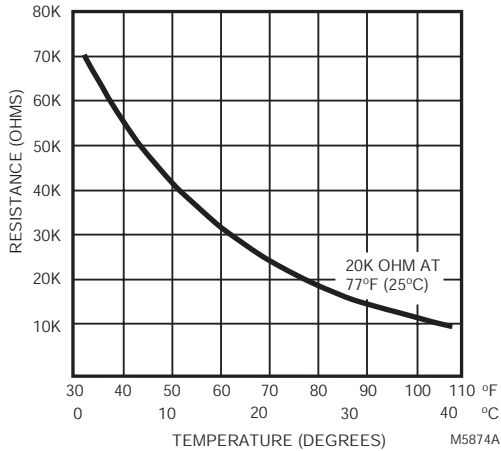

Fig. 1. Temperature vs. resistance for nonlinear sensor.

**Communications:**

Includes a LONMARK® bus communications port. If needed, the jack plug must be removed in the field, and terminals 1 and 2 wired according to the installation instructions to minimize installation errors due to miswiring.

The recommended wire size for the LONMARK® bus is Level IV, 22 AWG (0.34 sq.mm) plenum or non-plenum rated, nonshielded, twisted pair, solid conductor wire.

**Wall Module Bypass Override/LED Operation**

When the T7771 override button is pushed, the T7350 setting changes to Temporary Occupied. If pressed again, the T7350 setting changes back to Occupied. The override button has no effect when the T7350 programmed setting is already Occupied.

**BEFORE INSTALLATION**

**Cover Disassembly**

One locking mechanism is used on the wall module cover. After installation, to disassemble the cover and the subbase see Fig. 2.

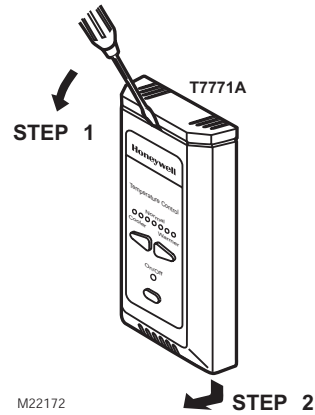

Fig. 2. Cover disassembly.



**CAUTION**

**Erratic System Operation Hazard.**  
**Failure to follow proper wiring practices can introduce disruptive electrical interference (noise).**  
 Keep wiring at least one foot away from large inductive loads such as motors line starters, lighting ballasts, and large power distribution panels.  
 Shielded cable is required in installations where these guidelines cannot be met.  
 Ground shield only to grounded controller case.

**IMPORTANT**

*All wiring must comply with local electrical codes and ordinances or as specified on installation wiring diagrams.*

- Wall module wiring can be sized from 14 to 22 AWG (2.0 to 0.34 sq mm) depending on the application.
- The maximum length of wire from a device to a wall module is 1000 ft (305m).
- Twisted pair wire is recommended for wire runs longer than 100 ft (30.5m).
- The cover for the wall module is packed separately from the subbase for ease of installation.

See Fig. 3 to release/replace the subbase terminal block.

**ORDERING INFORMATION**

When purchasing replacement and modernization products from your TRADELINE® wholesaler or distributor, refer to the TRADELINE® Catalog or price sheets for complete ordering number.

If you have additional questions, need further information, or would like to comment on our products or services, please write or phone:

1. Your local Honeywell Automation and Control Products Sales Office (check white pages of your phone directory).
2. Honeywell Customer Care  
 1885 Douglas Drive North  
 Minneapolis, Minnesota 55422-4386

In Canada—Honeywell Limited/Honeywell Limitée, 35 Dynamic Drive, Scarborough, Ontario M1V 4Z9.

International Sales and Service Offices in all principal cities of the world. Manufacturing in Australia, Canada, Finland, France, Germany, Japan, Mexico, Netherlands, Spain, Taiwan, United Kingdom, U.S.A.

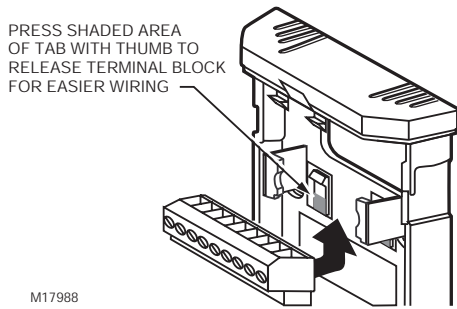

M17988

Fig. 3. Releasing/replacing terminal block.

## INSTALLATION



### CAUTION

**Equipment Damage Hazard.**  
Electrostatic discharge can short equipment circuitry.

Ensure that you are properly grounded before handling the unit.

Touch only the plastic cover, casing, and buttons.

Mount the T7771A Wall Module on an inside wall approximately 54 in. (1372 mm) from the floor (or in the specified location) to allow exposure to the average zone temperature. Do not mount the wall module on an outside wall, on a wall containing waterpipes or near air ducts. Avoid locations that are exposed to discharge air from registers or radiation from lights, appliances, or the sun.

The wall module can be mounted on a wall, on a standard utility conduit box using No. 6 (3.5 mm) screws or on a 60 mm wall outlet box (see Fig. 5). When mounting directly on a wall, use the type of screws appropriate for the wall material.

NOTE: See Fig. 4 for subbase mounting dimensions.

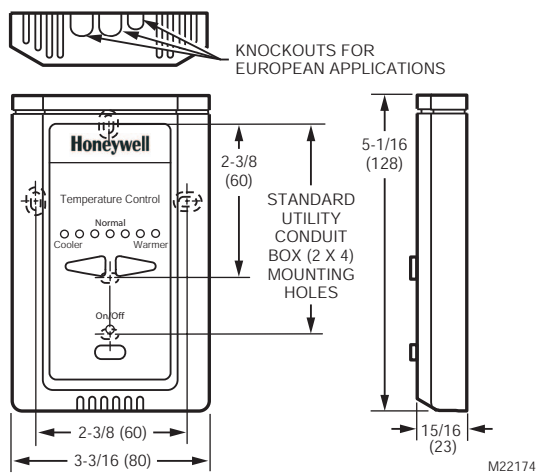

M22174

Fig. 4. T7771A Subbase dimensions in in. (mm).

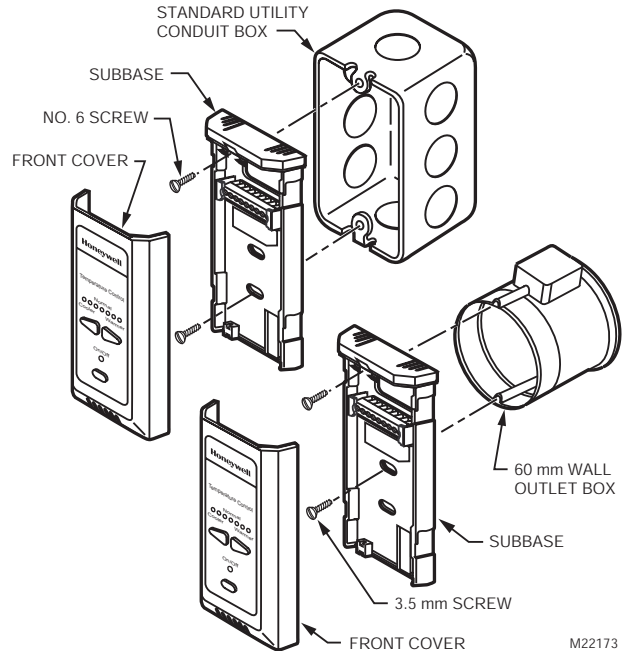

M22173

Fig. 5. Mounting wall modules on standard utility conduit box or 60 mm wall outlet box.

## Wiring

Attach the wires from the device sensor terminals to the appropriate wall module terminals. See Fig. 6.



### CAUTION

**Improper Electrical Contact Hazard.**  
Screw type terminal blocks are designed to accept no more than one 14 AWG (2.5 sq mm) conductor. Connect multiple wires that are 14 AWG (2.5 sq mm) with a wire nut. Include a pigtail with this wire group and attach the pigtail to the individual terminal block.

Wire the terminal blocks as follows:

1. For single wires, strip 3/16 in. (5 mm); for multiple wires going into one terminal, strip 1/2 in. (13 mm) insulation from the conductor.
2. If two or more wires are being inserted into one terminal, twist the wires together before inserting.

NOTE: When two or more wires are being inserted into one terminal, be sure to twist them together. Deviation from this rule can result in improper electrical contact. See Fig. 9.

3. Insert the wire in the required terminal location and tighten the screw to complete the termination.
4. Verify wall module wiring with Fig. 6.

NOTE: Wire the E-Bus using Level IV 22 AWG (0.34 sq mm) plenum or non-plenum rated, unshielded, twisted pair, solid conductor wire.

### Averaging Multiple Sensors

The default position for the J2 jumper is 20K ohms. When using a single sensor, leave the jumper in this position.

For temperature averaging using a T7350 Commercial Thermostat and multiple sensors, use the following guidelines:

- Only one T7771 can be used.
- For the second sensor, use a T7770A3002 (which has a 10K ohm output).
- Wire the two sensors in series.

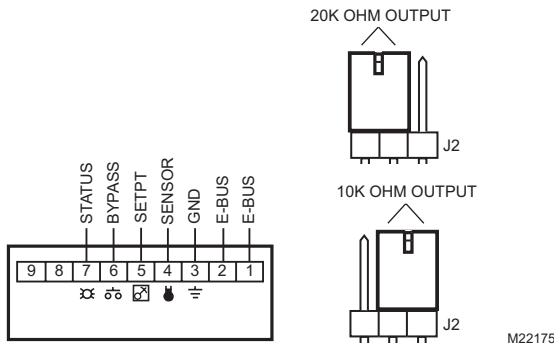

Fig. 6. Wiring diagram for T7771A Wall Modules.

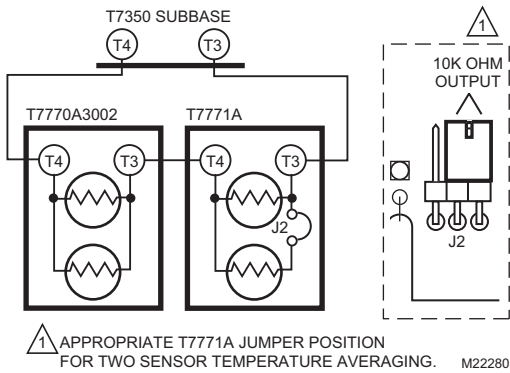

Fig. 7. Temperature averaging with two sensors.

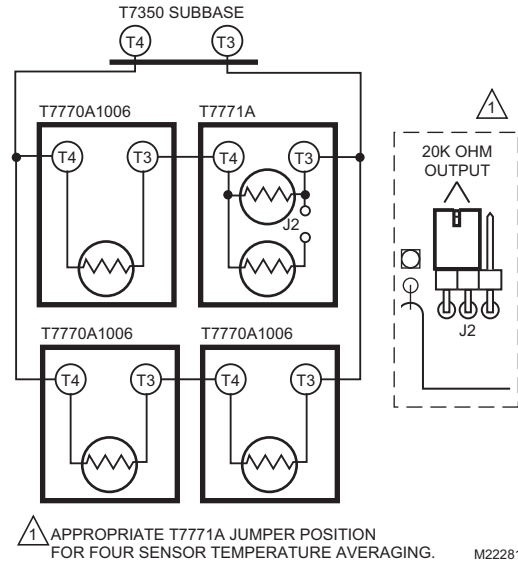

Fig. 8. Temperature averaging with four sensors.

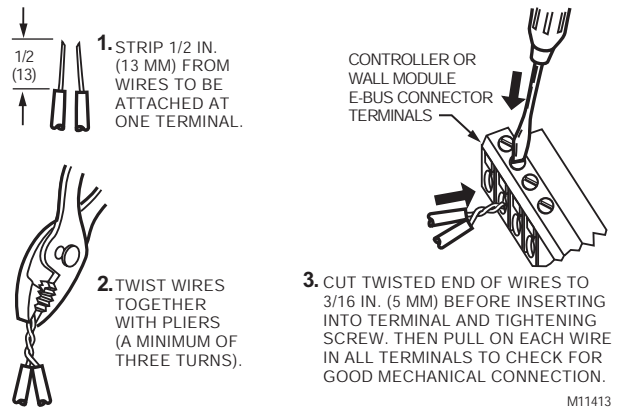

Fig. 9. Attaching two wires at wall module terminals.

When all wiring is complete, attach the cover of the T7771A Wall Module by reversing step 2 of Fig. 2.



#### Automation and Control Solutions

Honeywell International Inc.  
1985 Douglas Drive North  
Golden Valley, MN 55422

Honeywell Limited-Honeywell Limitée  
35 Dynamic Drive  
Scarborough, Ontario  
M1V 4Z9

#### ACS Control Products

Honeywell AG  
Böblinger Straße 17  
D-71101 Schönaich  
Phone (49-7041) 637-01  
Fax (49-7041) 637-493

